

Protective Face Shield v2

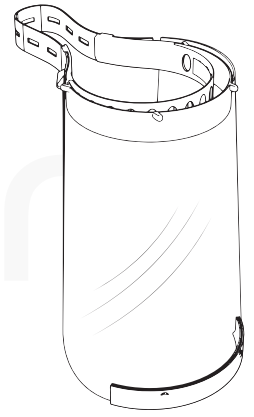

Anti-fogging

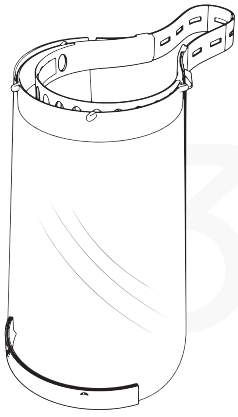

Antibacterial

For your personal mask you need :

Hole puncher / Scissors / Button Hole Elastic Band / CD

Step 1

Place the hole puncher in the bottom center and punch. For the next step, turn the foil so that the holes are at the top.

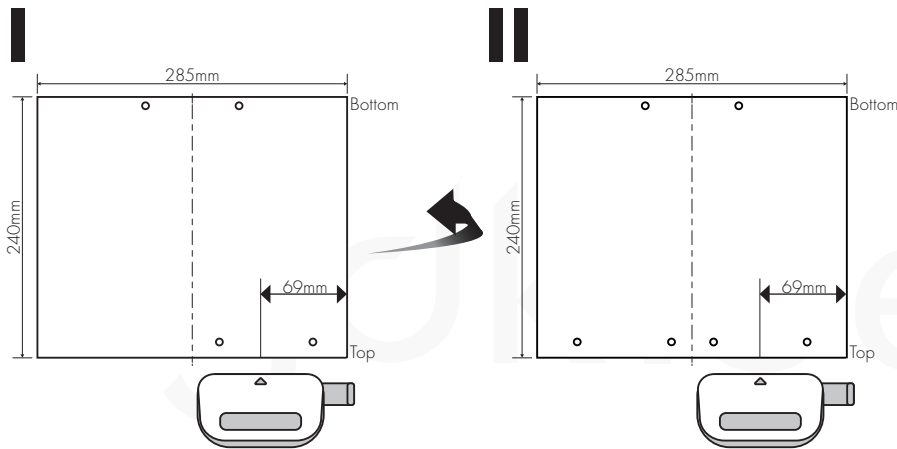
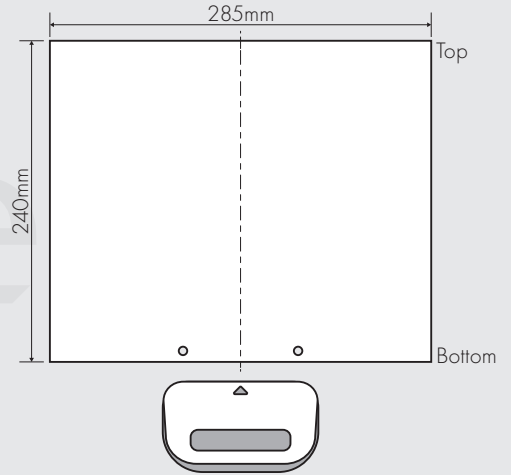

Step 2

First set the hole punch's alignment bar to 888 or 3x8 and then punch the foil on the top side (facing to you) from the right, flip the foil and punch again from the right.

Step 3

Pick up a CD or something with a comparable radius and mark the radius on the bottom side left and right. Cut along the marks with a pair of scissors.

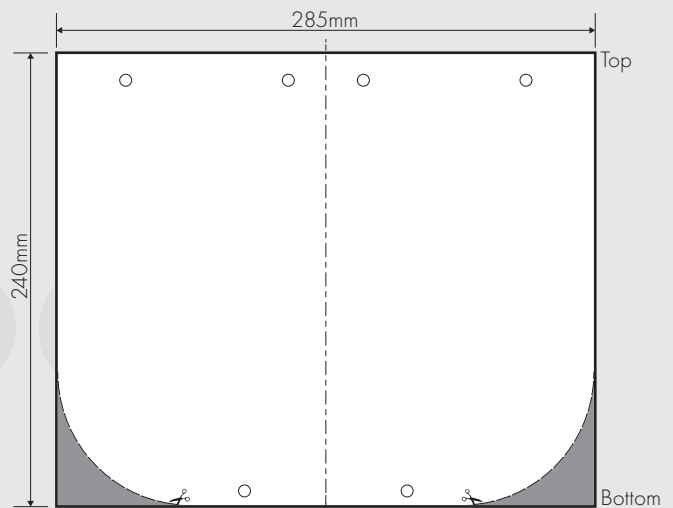

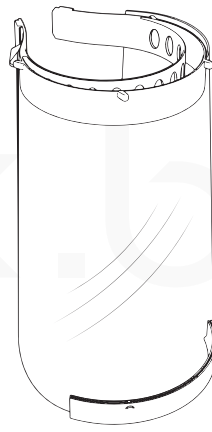
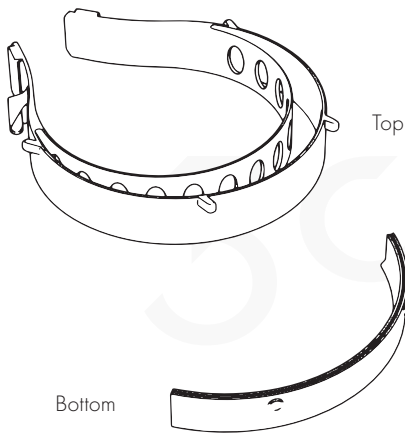

Step 4

Insert the foil into the upper and lower part of the mask.

Step 5

Take the button hole elastic band and attach it to one side. Thread the band through the tabs and adjust the length to fit your head size. Then attach it to the other side.

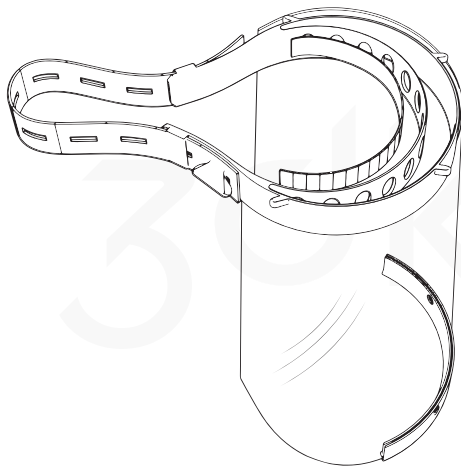
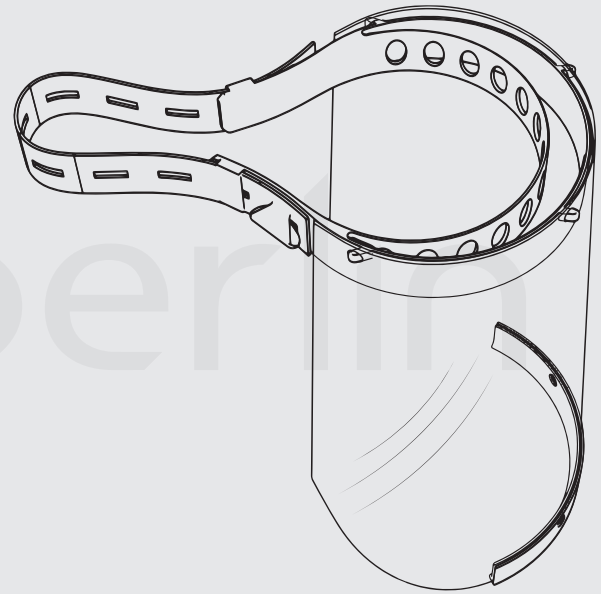

Optional Step 6

You can increase the comfort, by sticking some foam rubber to the headband.

This is not 100% protection against the CoVID19 virus, it only protects your mucous membranes from direct droplet infection.

It still applies:
keep your distance
wash your hands regularly
avoid gatherings

Your 3dk.berlin team wishes everyone stamina and hopes for a speedy improvement.

www.3dk.berlin - spritzschutz@3dk.berlin - Ruppinerchaussee 325 13503 Berlin - 030 54909613

ATTENTION: The Protective Face Shield V2 we supply have not been disinfected during production. If necessary, please disinfect them before first use.